

ASSEMBLY DOCTOR PAINT-IT 2 QPAR51 / GU-10 50W

design Nuuv for dark

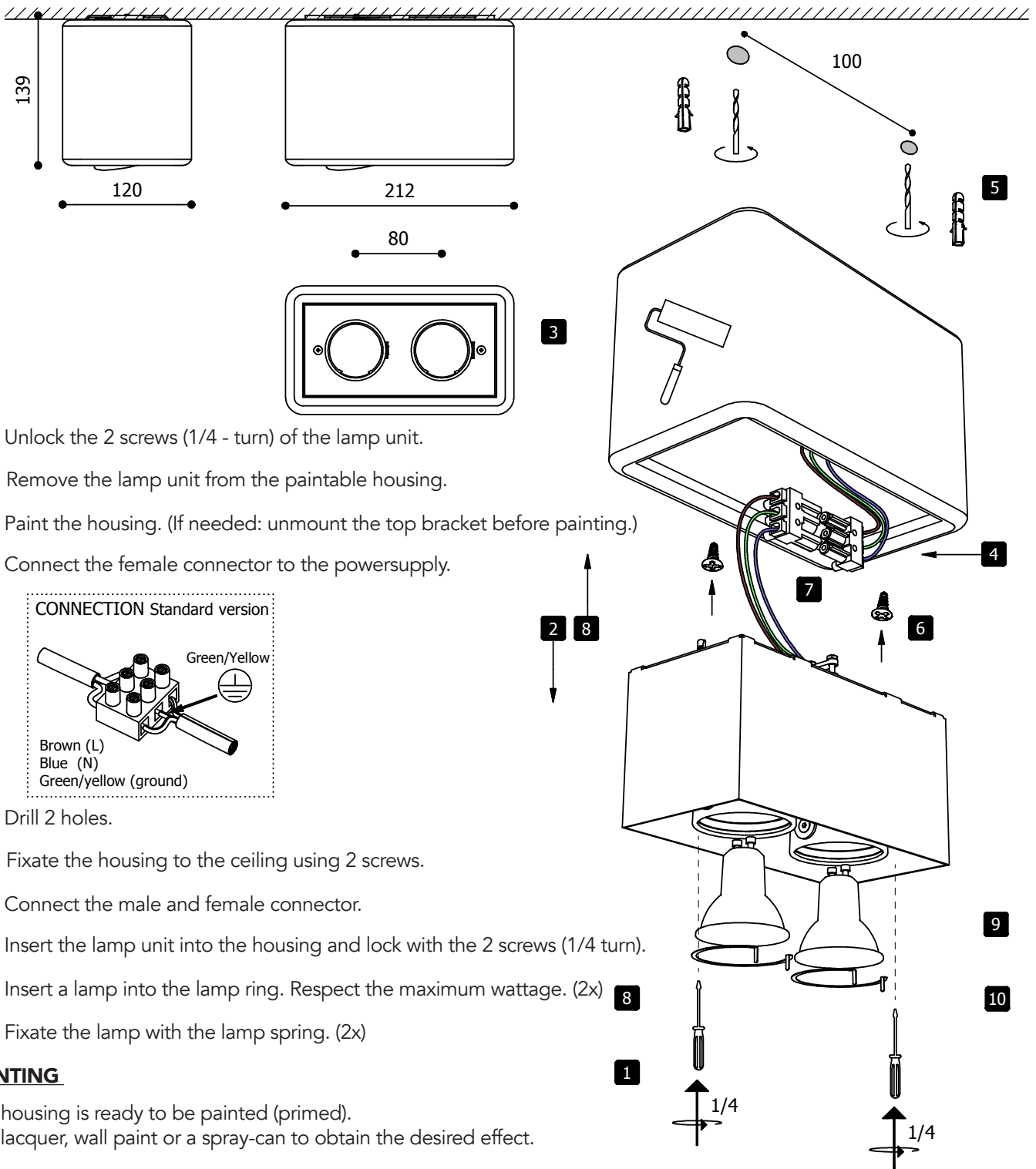

- 1 Unlock the 2 screws (1/4 - turn) of the lamp unit.
- 2 Remove the lamp unit from the paintable housing.
- 3 Paint the housing. (If needed: unmount the top bracket before painting.)
- 4 Connect the female connector to the powersupply.

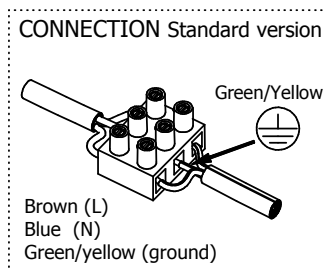

- 5 Drill 2 holes.
- 6 Fixate the housing to the ceiling using 2 screws.
- 7 Connect the male and female connector.
- 8 Insert the lamp unit into the housing and lock with the 2 screws (1/4 turn).
- 9 Insert a lamp into the lamp ring. Respect the maximum wattage. (2x)
- 10 Fixate the lamp with the lamp spring. (2x)

PAINTING

The housing is ready to be painted (primed).
Use lacquer, wall paint or a spray-can to obtain the desired effect.

LIGHT SOURCE

Touching the LED can result in permanent damage of the light source.
The light source contained in this luminaire shall only be replaced by the manufacturer or his service agent or a similar qualified person.
Always be properly grounded when touching leads or circuitry inside the luminaire.

!!! Never connect the fixture on 220-240V ac without driver.

Lighting fixture is constant current driven.
For drivers purchase, contact your sales contact.
Always connect constant current leds in serial connection.

Check catalogue P 488-489 (Installation of LED)

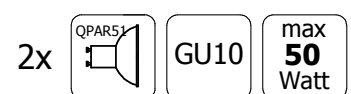

ASSEMBLY DOCTOR PAINT-IT 2 LED

design Nuuv for dark

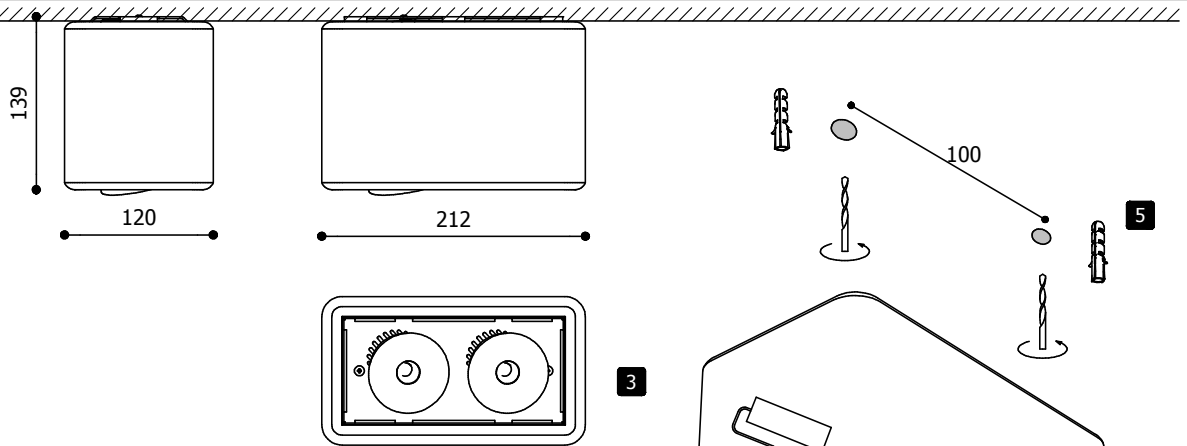

- 1 Unlock the 2 screws (1/4-turn) of the lamp unit.
- 2 Remove the lamp unit from the paintable housing.
- 3 Paint the housing. (If needed: unmount the top bracket before painting.)
- 4 (If needed connect the driver and the male connector to the driver) Connect the female connector to the powersupply + the dimming cables.

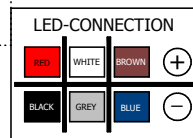
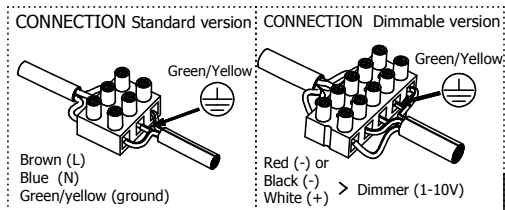

- 5 Drill 2 holes.
- 6 Fixate the housing to the ceiling using 2 screws.
- 7 Connect the male and female connector.
- 8 Insert the lamp unit into the housing and lock with 2 screws (1/4 turn).
- 9 Put the power on.

PAINTING

If you ordered the paintable version: the housing is ready to be painted (primed). Use lacquer, wall paint or a spray-can to obtain the desired effect.

LIGHT SOURCE

Touching the LED can result in permanent damage of the light source. The light source contained in this luminaire shall only be replaced by the manufacturer or his service agent or a similar qualified person. Always be properly grounded when touching leads or circuitry inside the luminaire.

!!! Never connect the fixture on 220-240V ac without driver.

Lighting fixture is constant current driven.
For drivers purchase, contact your sales contact.
Always connect constant current leds in serial connection.

Check catalogue P 488-489 (Installation of LED)

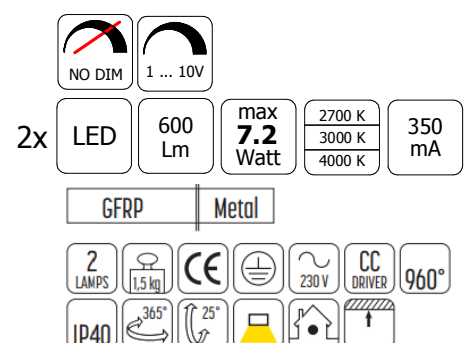

ASSEMBLY DOCTOR PAINT-IT 2 QR-CB-C51/ GU-5.3 35W design Nuuv for dark

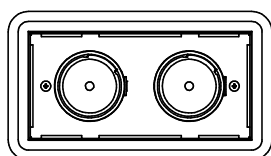
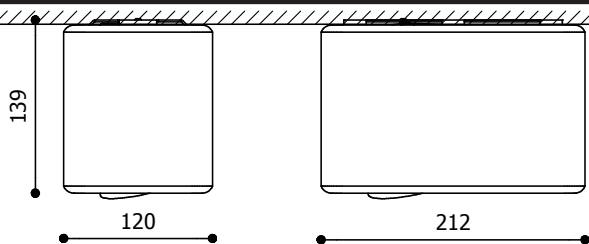

- 1 Unlock the 2 screws (1/4-turn) of the lamp unit.
- 2 Remove the lamp unit from the paintable housing.
- 3 Paint the housing. (If needed: unmount the top bracket before painting.)
- 4 Connect the female connector to the powersupply.

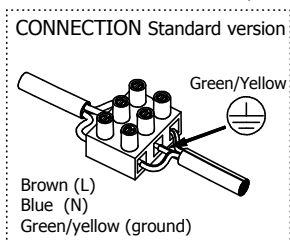

- 5 Drill 2 holes.
- 6 Fixate the housing to the ceiling using 2 screws.
- 7 Connect the male and female connector.
- 8 Insert the lamp unit into the housing and lock with 2 screws (1/4 turn).
- 9 Insert a lamp into the lamp ring. Respect the maximum wattage. (2x)
- 10 Fixate the lamp with the lamp spring. (2x)

PAINTING

The housing is ready to be painted (primed).
Use lacquer, wall paint or a spray-can to obtain the desired effect.

LIGHT SOURCE

Touching the LED can result in permanent damage of the light source.
The light source contained in this luminaire shall only be replaced by the manufacturer or his service agent or a similar qualified person.
Always be properly grounded when touching leads or circuitry inside the luminaire.

!!! Never connect the fixture on 220-240V ac without driver.

Lighting fixture is constant current driven.
For drivers purchase, contact your sales contact.
Always connect constant current leds in serial connection.

Check catalogue P 488-489 (Installation of LED)

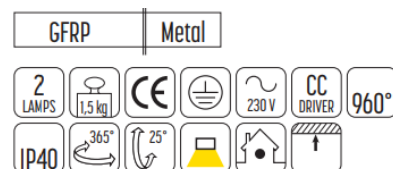
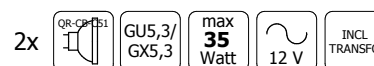
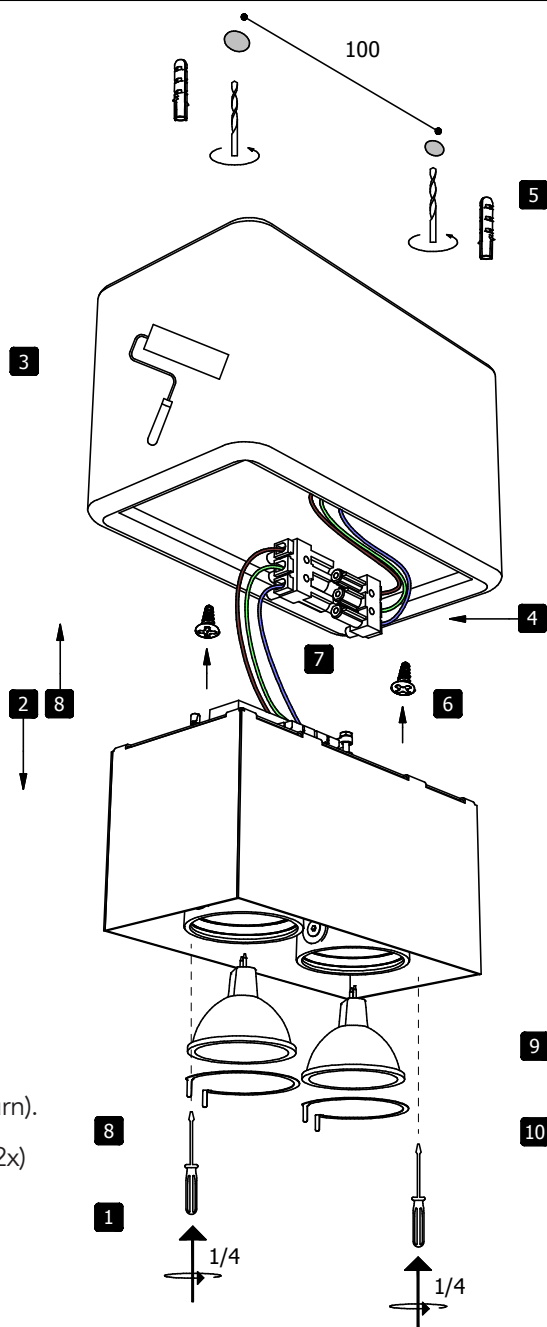

ASSEMBLY DOCTOR PAINT-IT 3 LED

design Nuuv for dark

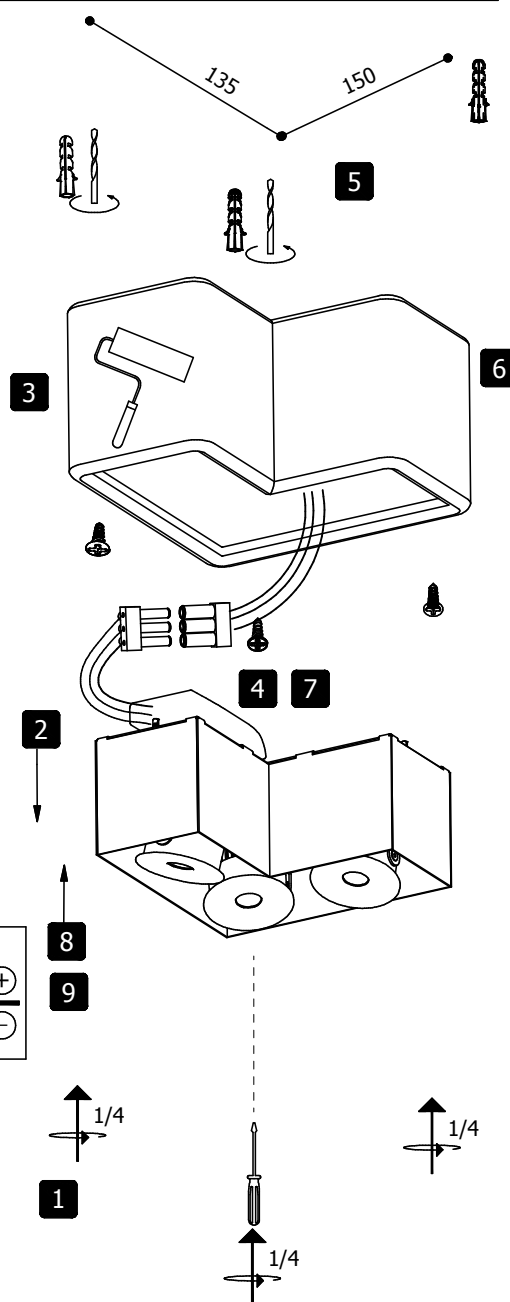
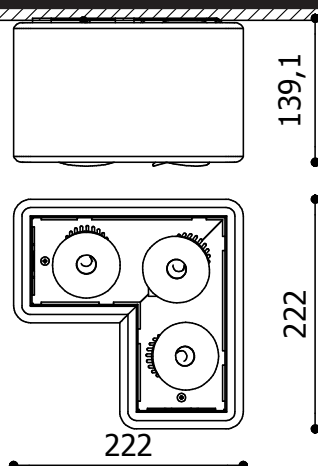

- 1 Unlock the 3 screws (1/4-turn) of the lamp unit.
- 2 Remove the lamp unit from the paintable housing.
- 3 Paint the housing. (If needed: unmount the top bracket before painting.)
- 4 (If needed connect the driver and the male connector to the driver) Connect the female connector to the powersupply + the dimming cables.

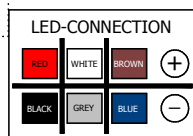
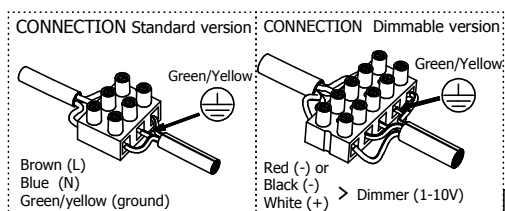

- 5 Drill 3 holes.
- 6 Fixate the housing to the ceiling using 3 screws.
- 7 Connect the male and female connector.
- 8 Insert the lamp unit into the housing and lock with 3 screws (1/4 turn).
- 9 Put the power on.

PAINTING

If you ordered the paintable version: the housing is ready to be painted (primed). Use lacquer, wall paint or a spray-can to obtain the desired effect.

LIGHT SOURCE

Touching the LED can result in permanent damage of the light source. The light source contained in this luminaire shall only be replaced by the manufacturer or his service agent or a similar qualified person. Always be properly grounded when touching leads or circuitry inside the luminaire.

!!! Never connect the fixture on 220-240V ac without driver.

Lighting fixture is constant current driven. For drivers purchase, contact your sales contact. Always connect constant current leds in serial connection.

Check catalogue P 488-489 (Installation of LED)

Lamp possibilities :

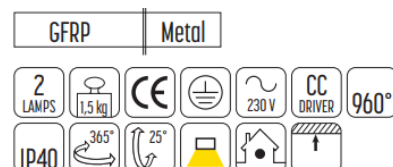
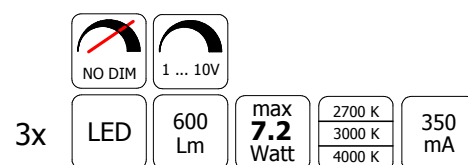

ASSEMBLY DOCTOR PAINT-IT 3 QR-CB-C51/ GU-5.3 35W design Nuuv for dark

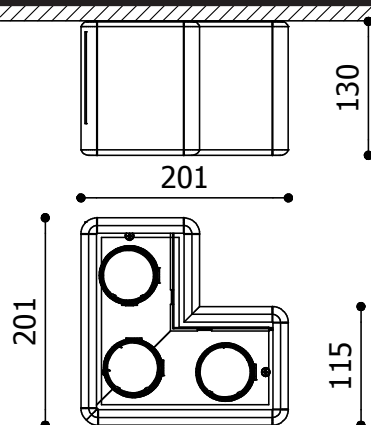

- 1 Unlock the 3 screws (1/4-turn) of the lamp unit.
- 2 Remove the lamp unit from the paintable housing.
- 3 Paint the housing. (If needed: unmount the top bracket before painting.)
- 4 Connect the female connector to the powersupply.

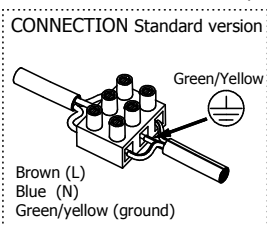

5. Drill 3 holes.

- 5 Drill 3 holes.
- 6 Fixate the housing to the ceiling using 3 screws.
- 7 Connect the male and female connector.
- 8 Insert the lamp unit into the housing and lock with 3 screws (1/4 turn).
- 9 Insert a lamp into the lamp ring. Respect the maximum wattage. (3x)
- 10 Fixate the lamp with the lamp spring. (3x)

PAINTING

The housing is ready to be painted (primed).
Use lacquer, wall paint or a spray-can to obtain the desired effect.

LIGHT SOURCE

Touching the LED can result in permanent damage of the light source.
The light source contained in this luminaire shall only be replaced by the manufacturer or his service agent or a similar qualified person.
Always be properly grounded when touching leads or circuitry inside the luminaire.

!!! Never connect the fixture on 220-240V ac without driver.

Lighting fixture is constant current driven.
For drivers purchase, contact your sales contact.
Always connect constant current leds in serial connection.

Check catalogue P 488-489 (Installation of LED)

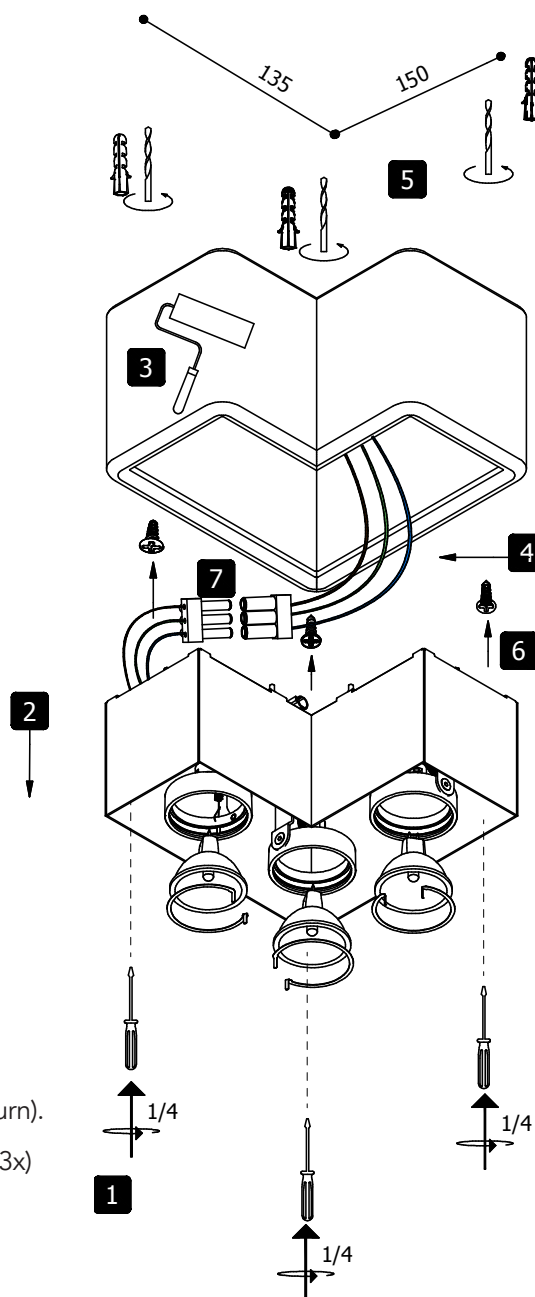

Lamp possibilities :

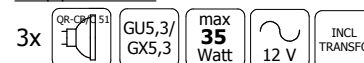

GFRP | Metal



ASSEMBLY DOCTOR PAINT-IT 5

design Nuuv for dark

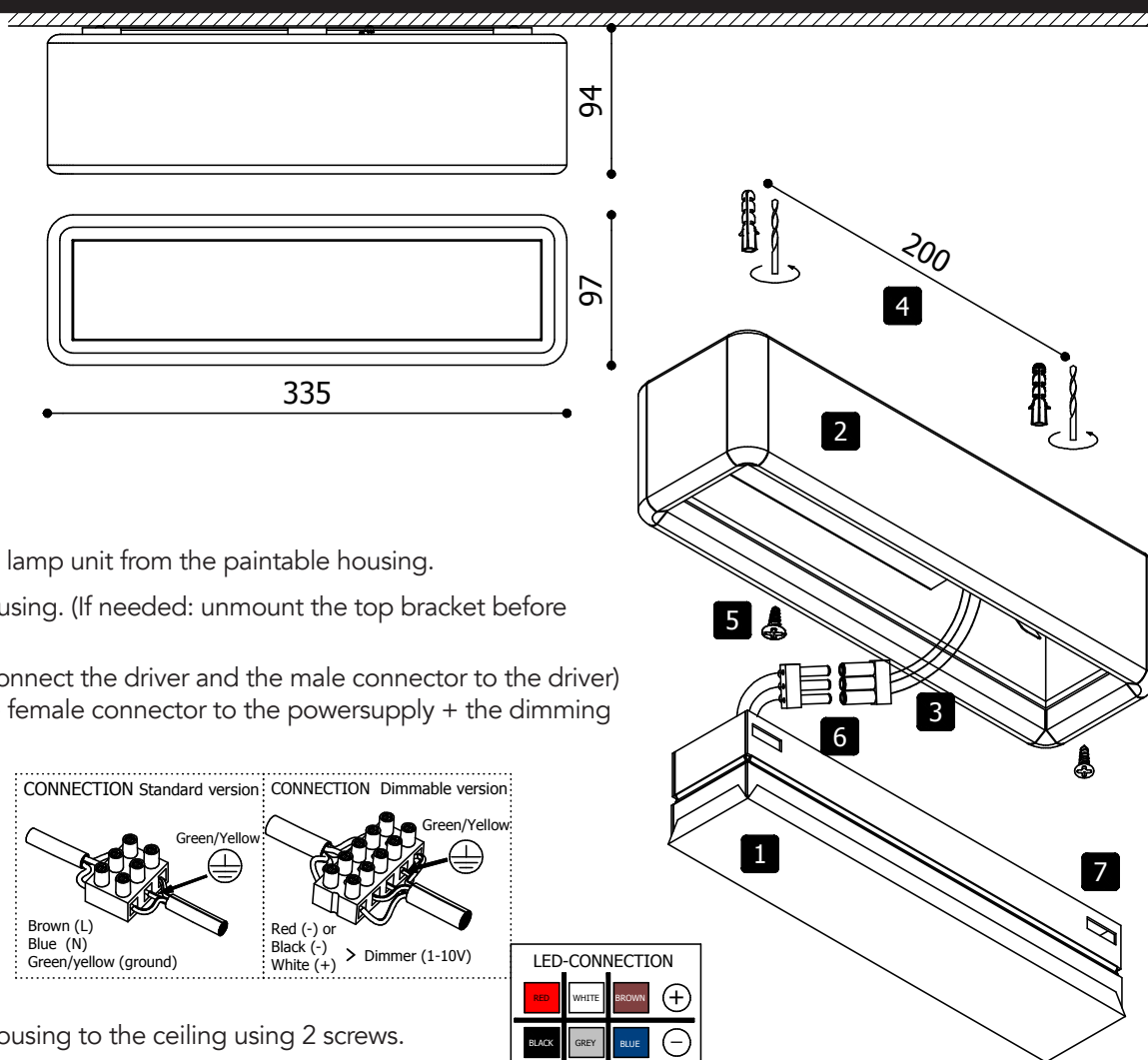

- 1 Remove the lamp unit from the paintable housing.
- 2 Paint the housing. (If needed: unmount the top bracket before painting.)
- 3 (If needed connect the driver and the male connector to the driver) Connect the female connector to the powersupply + the dimming cables.

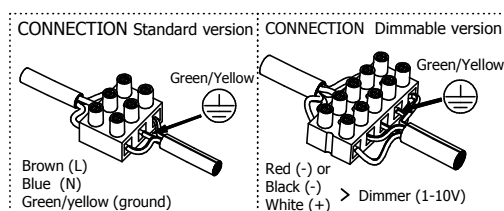

- 4 Drill 2 holes.
- 5 Fixate the housing to the ceiling using 2 screws.
- 6 Connect the male and female connector.
- 7 Insert the lamp unit into the housing until the lamp unit snaps fit.
- 8 Put the power on.

PAINTING

If you ordered the paintable version: the housing is ready to be painted (primed). Use lacquer, wall paint or a spray-can to obtain the desired effect.

LIGHT SOURCE

Touching the LED can result in permanent damage of the light source. The light source contained in this luminaire shall only be replaced by the manufacturer or his service agent or a similar qualified person. Always be properly grounded when touching leads or circuitry inside the luminaire.

!!! Never connect the fixture on 220-240V ac without driver.

Lighting fixture is constant current driven. For drivers purchase, contact your sales contact. Always connect constant current leds in serial connection.

Check catalogue P 488-489 (Installation of LED)

Lamp possibilities :

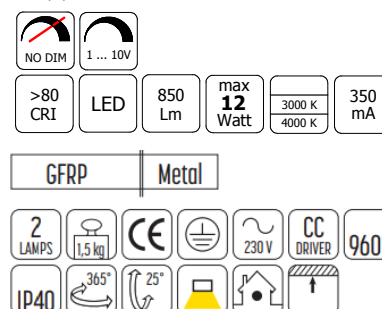

ASSEMBLY DOCTOR PAINT-IT WALL

design Nuuv for dark

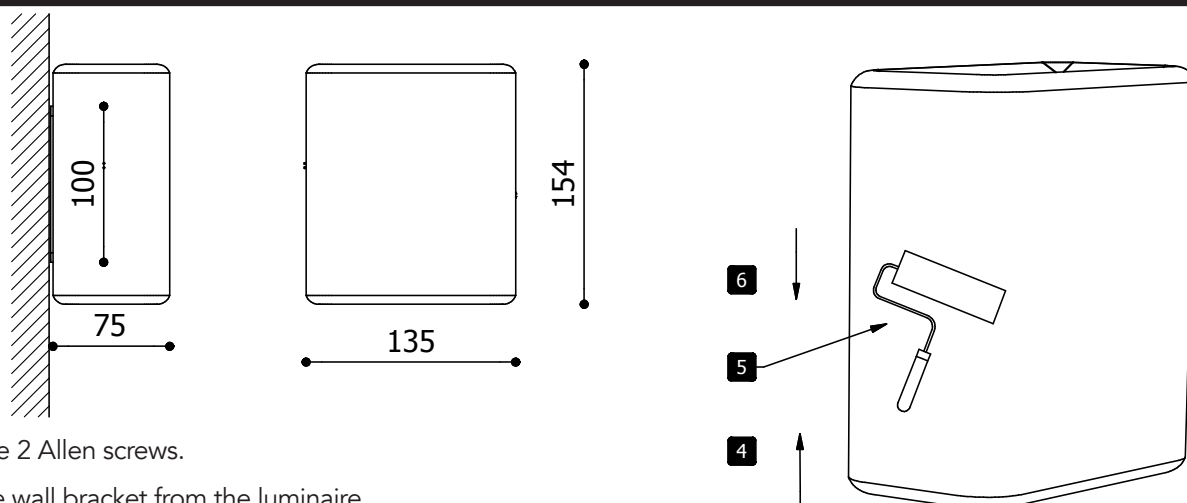

- 1 Unscrew the 2 Allen screws.
- 2 Remove the wall bracket from the luminaire.
- 3 Attach the wall bracket to the wall using 2 screws.
- 4 Slide the LED unit out of the paintable housing.
- 5 Paint the housing.
- 6 Slide the LED unit back into the paintable housing.

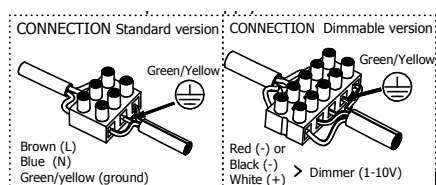

- 7 Connect the power supply
- 8 Place the luminaire on the wall bracket.
- 9 Fixate the luminaire with the 2 Allen screws.

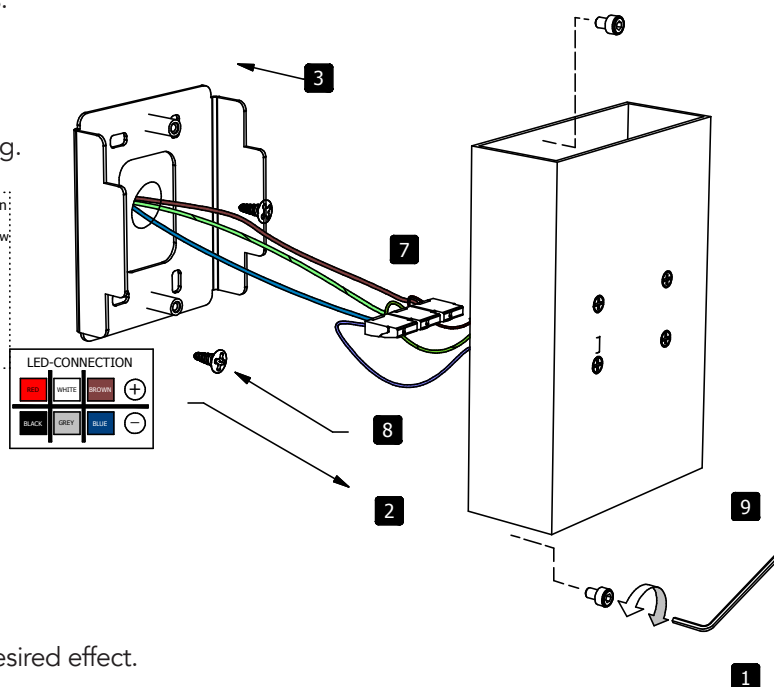

PAINTING

The housing is ready to be painted (primed).
Use lacquer, wall paint or a spray-can to obtain the desired effect.

IMPORTANT NOTICE

To avoid permanent damage to the LED:

- The power supply must be switched off during installation.
- Do not touch the LED.

LIGHT SOURCE

Touching the LED can result in permanent damage of the light source.
The light source contained in this luminaire shall only be replaced by the manufacturer or his service agent or a similar qualified person.
Always be properly grounded when touching leads or circuitry inside the luminaire.

!!! Never connect the fixture on 220-240V ac without driver.

Lighting fixture is constant current driven.
For drivers purchase, contact your sales contact.
Always connect constant current leds in serial connection.

Check catalogue P 488-489 (Installation of LED)

Dimming possibilities :

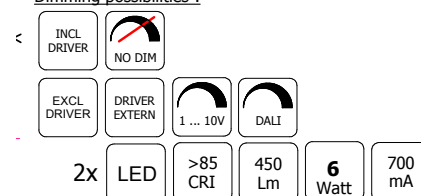

GFRP | Metal



NEDERLANDS

ALGEMENE GEBRUIKSVORWAARDEN

- Het toestel dient geplaatst, aangesloten en uitgetest te worden door een erkend installateur en volgens de plaatselijk geldende reglementering.
- De klant wordt verondersteld onze algemene verkoopvoorwaarden te kennen.
- De lampen dienen steeds met zorg te worden geïnstalleerd of vervangen.
- Overschrijdt nooit de maximum aangeduide wattage op het toestel.
- Voor installatie of onderhoud van het toestel de voedingsspanning afsluiten.
- Bij lampvervanging het toestel afzetten en volledig laten afkoelen.
- Het toestel kan worden onderhouden met een zachte doek en eventueel een standaard pH-neutraal detergent. Voor goederen met een inox oppervlak moet dit op geregelde tijdstippen gebeuren. Het toestel moet hiervoor worden afgezet en volledig afgekoeld.
- Elk verkeerd gebruik of aanpassing van het toestel maakt de garantie nietig. Kinderen moeten buiten het bereik van de toestellen worden gehouden, aangezien de temperatuur van het toesteloppervlak hoog kan oplopen.
- De toestellen mogen nooit worden bedekt zoals bijvoorbeeld met een isolerend materiaal of iets dergelijks.

ER KUNNEN WIJZIGINGEN OPTREDEN QUA ONTWERP, SPECIFICATIES EN MONTAGE-INSTRUCTIES.

DEUTSCH

ALLGEMEINE GEBRAUCHSBEDINGUNGEN

- Das Gerät soll von einem anerkannten Installateur und den örtlich geltenden Satzungen gemäß aufgestellt, angeschlossen und getestet werden.
- Der Kunde soll unsere allgemeinen Verkaufsbedingungen kennen.
- Die Lampen sollen immer sorgfältig installiert oder ersetzt werden.
- Sie sollen die angegebene maximale Wattleistung, die auf dem Gerät angegeben ist, nie überschreiten.
- Für die Installation oder die Wartung des Geräts sollen Sie die Spannung abschließen.
- Wenn Sie Lampen ersetzen, sollen Sie das Gerät ausschalten und völlig abkühlen lassen.
- Für die Wartung des Geräts benutzen Sie ein weiches Tuch und eventuell ein reguläres pH - neutrales Reinigungsmittel. Für Güter mit einer Oberfläche aus Edelstahl soll dies regelmäßig gemacht werden. Dafür soll das Gerät ausgeschaltet und völlig abgekühlt werden.
- Jede falsche Benutzung oder Anpassung des Geräts macht die Garantie ungültig.
- Diese Geräte sollen außer Reichweite von Kindern gehalten werden, da die Temperatur der Oberfläche des Geräts stark ansteigen kann.
- Die Geräte dürfen nie mit zum Beispiel einem isolierendem Material oder etwas Ähnlichem bedeckt werden.

ÄNDERUNGEN IM ENTWURF, IN SPEZIFIZIERUNGEN UND MONTAGEANWEISUNGEN SIND MÖGLICH.

ESPAÑOL

CONDICIONES GENERALES DE USO

- El aparato tiene que ser colocado, conectado y probado por un técnico reconocido, respetando el reglamento local vigente.
- Se supone que el cliente conoce nuestras condiciones generales de venta.
- Las lámparas siempre tienen que ser instaladas o reemplazadas con cuidado.
- No se puede nunca sobrepasar el vataje máximo que está indicado en el aparato.
- Corte la alimentación eléctrica antes de instalar o mantener el aparato.
- Desconecte el aparato y déjelo enfriar completamente antes de reemplazar las lámparas.
- Para el mantenimiento del aparato se puede utilizar un paño suave o, eventualmente, un detergente estándar de pH-neutro. Cuando se trata de aparatos con una superficie de acero inoxidable, el mantenimiento tiene que ser efectuado con regularidad. Para la limpieza hay que desconectar y dejar enfriar el aparato completamente.
- Todo uso impropio o toda adaptación impropia del aparato implica la anulación de la garantía.
- Como el aparato puede alcanzar temperaturas considerables, los aparatos deben mantenerse fuera del alcance de los niños.
- No se puede cubrir nunca los aparatos con, por ejemplo, algún tipo de material aislante.

SON POSIBLES LAS MODIFICACIONES EN CUANTO AL DISEÑO, LAS ESPECIFICACIONES Y LAS INSTRUCCIONES DE MONTAJE.

FRANCAIS

CONDITIONS GÉNÉRALES D'UTILISATION

- L'appareil doit être placé, raccordé et testé par un installateur agréé et selon les réglementations locales en vigueur.
- Le client est censé connaître nos conditions générales de vente.
- Les lampes doivent en tout temps être installées ou remplacées avec soin.
- Ne jamais excéder le wattage maximum indiqué sur l'appareil.
- Déconnecter la tension d'alimentation de l'appareil avant installation ou entretien.
- Déconnecter l'appareil et le laisser refroidir entièrement avant de remplacer une lampe.
- L'appareil s'entretient à l'aide d'un chiffon doux et, éventuellement, d'un détergent au PH neutre. Pour les appareils à surface en inox, cet entretien doit s'effectuer à des intervalles réguliers. A cet effet, déconnecter l'appareil et le laisser refroidir entièrement.
- Toute utilisation erronée ou adaptation de l'appareil annule la garantie.
- Ne pas laisser les appareils à portée de main des enfants, étant donné que la température de la surface de l'appareil peut être élevée.
- Les appareils ne peuvent jamais être recouverts, comme par exemple d'un matériau isolant ou équivalent.

NOUS NOUS RÉSERVONS LE DROIT DE MODIFICATIONS AU NIVEAU CONCEPT, SPÉCIFICATIONS ET INSTRUCTIONS DE MONTAGE.

ENGLISH

GENERAL CONDITIONS FOR USE

- The appliance should be installed, connected and tested by a certified installer, and in accordance with the local regulations.
- The customer is supposed to know our general sales conditions.
- Lamps should always be installed or replaced with care.
- Never use a wattage higher than the maximum wattage mentioned on the appliance.
- Turn off the power supply before installation or maintenance of the appliance.
- When a lamp is to be replaced: switch off the appliance first and let it cool down completely.
- Clean the appliance with a soft cloth and a standard pH neutral detergent. Stainless steel surfaces should be maintained regularly. Therefore the appliance should be switched off and cooled down.
- Misuse of, or changes to the appliance shall nullify the guarantee.
- Keep children away from the appliances; the appliance's surface can be very hot.
- Never cover the appliances with e.g. insulating material.

THE MANUFACTURER IS FREE TO CHANGE THE DESIGN, SPECIFICATIONS AND INSTRUCTIONS FOR ASSEMBLY.

ITALIANO

CONDIZIONI GENERALI D'USO

- L'apparecchio deve essere installato, collegato e testato da un tecnico autorizzato, e secondo le regolazioni locali.
- Il cliente deve conoscere le nostre condizioni generali di vendita.
- Le lampadine devono sempre essere installate o sostituite con molta attenzione.
- Non usare mai una potenza in watt superiore a quella massima menzionata sull'apparecchio.
- dell'installazione o della manutenzione dell'apparecchio: interrompere l'alimentazione.
- Per sostituire una lampadina: disattivare l'apparecchio e lasciar raffreddare completamente.
- Mantenere l'apparecchio con un panno morbido, ed eventualmente imbevuto di un normale detergente con pH neutro. Le superfici inox devono essere mantenute con regolarità, perciò l'apparecchio deve essere disattivato e raffreddato completamente.
- Ogni uso dell'apparecchio non conforme alle istruzioni date e/o ogni modifica apportata ad esso, annulla la garanzia.
- Tener gli apparecchi fuori dalla portata di bambini, poiché la superficie dell'apparecchio può essere molto calda.
- Non coprire mai gli apparecchi: p.e. con un materiale isolante.

IL FABBRICANTE HA IL DIRITTO DI CAMBIARE IL PROGETTO, LE SPECIFICHE TECNICHE E LE ISTRUZIONI PER IL MONTAGGIO.